









1 GENERAL SAFETY PRECAUTIONS

Failure to respect the information given in this manual may cause personal injury or damage to the device.
 This installation manual is intended for qualified personnel only.
 ROGER TECHNOLOGY cannot be held responsible for any damage or injury due to improper use or any use other than the intended usage indicated in this manual. Installation, electrical connections and adjustments must be performed by qualified personnel, in accordance with best practices and in compliance with applicable regulations.
 Read the instructions carefully before installing the product. Bad installation could be dangerous.
 Before installing the product, make sure it is in perfect condition: if in doubt, do not use the equipment and contact qualified personnel only.
 Do not install the product in explosive areas and atmospheres: the presence of inflammable gas or fumes represents a serious safety hazard.
 Before installing the motorisation device, make all the necessary structural modifications to create safety clearance and to guard or isolate all the crushing, shearing, trapping and general hazardous areas.
 Make sure the existing structure is up to standard in terms of strength and stability.
 ROGER TECHNOLOGY is not responsible for failure to observe Good Working Methods when building the frames to be motorised, or for any deformation during use.
 The safety devices (photocells, safety edges, emergency stops, etc.) must be installed taking into account: applicable laws and directives, Good Working Methods, installation premises, system operating logic and the forces developed by the motorised door or gate.
 The safety devices must protect against crushing, cutting, trapping and general danger areas of the motorised door or gate.
 The European standards EN 12453 and EN 12445 define the minimum safety requirements for the operation of automatic doors and gates. In particular, these standards require the use of force limiting and safety devices (sensing ground plates, photocell barriers, operator detection function etc.) intended to detect persons or objects in the operating area and prevent collisions in all circumstances.
 Where the safety of the installation is based on an impact force limiting system, it is necessary to verify that the characteristics and performance of the automation system are compliant with the requisites of applicable standards and legislation.
 The installer is required to measure impact forces and programme the control unit with appropriate speed and torque values to ensure that the door or gate remains within the limits defined by the standards EN 12453 and EN 12445.
 ROGER TECHNOLOGY declines all responsibility if component parts not compatible with safe and correct operation are fitted.
 Display the signs required by law to identify hazardous areas.
 Each installation must bear a visible indication of the data identifying the motorised door or gate.
 An omnipolar disconnection switch with a contact opening distance of at least 3mm must be fitted on the mains supply.
 Make sure that upline from the mains power supply there is a residual current circuit breaker that trips at no more than 0.03A and overcurrent cutout upstream of the electrical system in accordance with best practices and in compliance with applicable regulations.
 When requested, connect the automation to an effective earthing system (⊕) that complies with current safety standards.
 During installation, maintenance and repair operations, cut off the power supply before opening the cover to access the electrical parts.
 The electronic parts must be handled using earthed antistatic conductive arms.
 Only use original spare parts for repairing or replacing products.
 The installer must supply all information concerning the automatic, manual and emergency operation of the motorised door or gate, and must provide the user with the operating instructions.
 The packaging materials (plastic, polystyrene, etc.) should not be discarded in the environment or left within reach of children, as they are a potential source of danger.
 Dispose of and recycle the packing components in accordance with the standards in force.
 These instructions must be kept and forwarded to all possible future user of the system.

2 SYMBOLS

The symbols and their meaning in the manual or on the product label are indicated below.

	Generic danger Important safety information. Indicates operations and situations in which the personnel involved must pay close attention.		Indicates the admissible temperature range.
	Useful information Indicates useful information for the installation.		Alternating current (AC)
	Refer to the Installation and use instructions Indicates the obligation to refer to the manual or original document, which must be available for future use and must not be damaged in any way.		Direct current (DC)
	Protective earth connection point.		Symbol for the product disposal according to the WEEE directive.

3 DECLARATION OF CONFORMITY

I the undersigned, as acting legal representative of the manufacturer:
Roger Technology - Via Botticelli 8, 31021 Bonisiolo di Mogliano V.to (TV)
 hereby DECLARE that the appliance described hereafter:
 Description: Automatic barrier
 Model: BIONIK1 - BIONIK4HP - BIONIK6 series
 Is conformant with the legal requisites of the following directives:
 • **2006/42/CE** (Machinery Directive) and subsequent amendments;
 • **2011/65/UE** (RoHS Directive) and subsequent amendments;
 • **2014/53/UE** (RED Directive);
 and that all the standards and/or technical requirements indicated as follows have been applied:
EN 61000-6-3, EN 61000-6-2; EN 60335-1

Last two figures of year in which marking was applied **CE 18**.

Place: Mogliano V.to

Date: 12/06/2018

Signature



4 INTENDED USE

The BIONIK automated barrier is specifically conceived for installations in private or public car parks, in residential, commercial or industrial areas or in high traffic zones. This product may only be used for its expressly intended purpose. Any other usage is prohibited.
 ROGER TECHNOLOGY cannot be held directly or indirectly responsible for any damage resulting from incorrect, inappropriate or unreasonable usage of this product.

5 LIMITATIONS USE

BIONIK barriers are suitable for VERY HEAVY DUTY operation and may be used with booms up to 6 metres in length.

6 DESCRIPTION OF THE PRODUCT

BI/001PE	BIONIK BRUSHLESS 36V $\overline{=}$ Barrier for bars up to 3 metres, with on-board control unit, absolute encoder, complete with fixing base with tie rods and screws, and boom fixing flange.
BI/004HP	BIONIK BRUSHLESS 36V $\overline{=}$ Barrier for bars up to 4 metres, with on-board control unit, absolute encoder, complete with fixing base with tie rods and screws, and boom fixing flange.
BI/004HP/115	BIONIK brushless 36V $\overline{=}$ Barrier for bars up to 4 metres, with on-board control unit, absolute encoder, complete with fixing base with tie rods and screws, and boom fixing flange. For line voltages of 115V.
BI/004HP/IS	BIONIK brushless 36V $\overline{=}$ Barrier for bars up to 4 metres, with on-board control unit, absolute encoder, complete with fixing base with tie rods and screws, and boom fixing flange. Frame made in Brushed stainless steel AISI 304.
BI/004HP/IS/115	BIONIK brushless 36V $\overline{=}$ Barrier for bars up to 4 metres, with on-board control unit, absolute encoder, complete with fixing base with tie rods and screws, and boom fixing flange. Frame made in Brushed stainless steel AISI 304. For line voltages of 115V.
BI/006	BIONIK brushless 36V $\overline{=}$ Barrier for bars up to 6 metres, with on-board control unit, absolute encoder, complete with fixing base with tie rods and screws, and boom fixing flange.
BI/006/115	BIONIK brushless 36V $\overline{=}$ Barrier for bars up to 6 metres, with on-board control unit, absolute encoder, complete with fixing base with tie rods and screws, and boom fixing flange. For line voltages of 115V.
BI/006/IS	BIONIK brushless 36V $\overline{=}$ Barrier for bars up to 6 metres, with on-board control unit, absolute encoder, complete with fixing base with tie rods and screws, and boom fixing flange. Frame made in Brushed stainless steel AISI 304.
BI/006/IS/115	BIONIK brushless 36V $\overline{=}$ Barrier for bars up to 6 metres, with on-board control unit, absolute encoder, complete with fixing base with tie rods and screws, and boom fixing flange. Frame made in Brushed stainless steel AISI 304. For line voltages of 115V.

7 STANDARD DIMENSIONS

BI/001PE

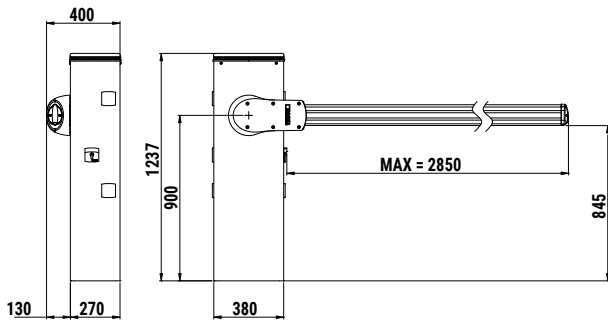

BI/004HP

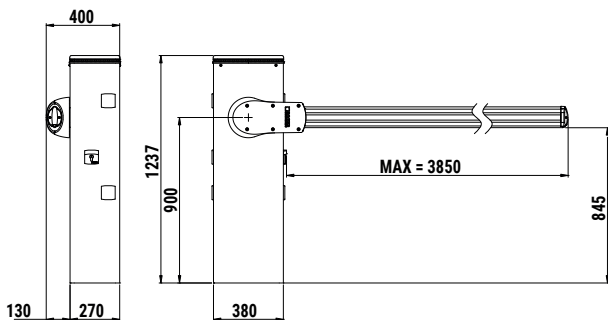

BI/006

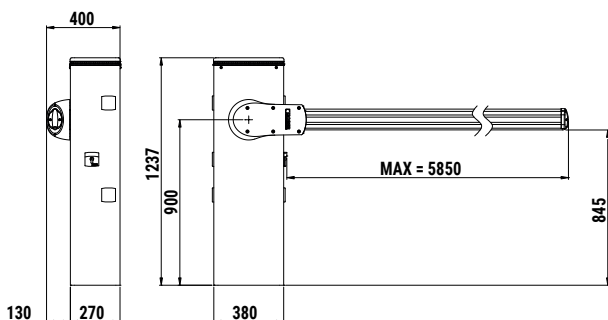

8 PACKAGE CONTENT

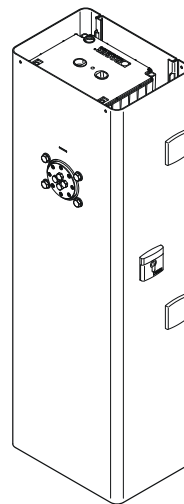

**COMPLETE BI/001/PE - BI/004HP - BI/006
BARRIER CABINET WITH INTEGRATED
CONTROL UNIT**



**ACCESSORIES
BOLTS AND SCREWS**

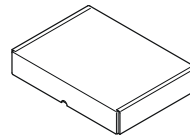

**HEAD COMPLETE WITH
DIFFUSER AND FLASHING
LAMP UNIT**

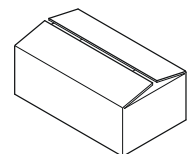

ASSEMBLED BOOMSUPPORT

All measurements are expressed in mm unless otherwise indicated.

9 TECHNICAL CHARACTERISTICS

SERIE BIONIK	BI/001PE	BI/004HP BI/004HP/IS	BI/004HP/115 BI/004HP/IS/115	BI/006 BI/006/IS	BI/006/115 BI/006/IS/115
POWER SUPPLY	230 Vac - 50 Hz ±10%	230 Vac - 50 Hz ±10%	115 Vac 60 Hz ±10%	230 Vac - 50 Hz ±10%	115 Vac 60 Hz ±10%
MOTOR POWER SUPPLY	36V $\overline{=}$	36V $\overline{=}$	36V $\overline{=}$	36V $\overline{=}$	36V $\overline{=}$
STARTING POWER	450 W	220 W	220 W	220 W	220 W
POWER CONSUMPTION	max 15 A	max 15 A	max 15 A	max 15 A	max 15 A
TORQUE	10÷200 Nm	10÷200 Nm	10÷200 Nm	10÷300 Nm	10÷300Nm
OPEN / CLOSE TIME	2 ÷ 4 sec	3 ÷ 6 sec	3 ÷ 6 sec	4 ÷ 8 sec	4 ÷ 8 sec
CONTROL SYSTEM	ABSOLUTE ENCODER DIGITAL	ABSOLUTE ENCODER DIGITAL	ABSOLUTE ENCODER DIGITAL	ABSOLUTE ENCODER DIGITAL	ABSOLUTE ENCODER DIGITAL
OPERATING CYCLES PER DAY (OPENING/CLOSING - 24 HOURS NO STOP) **	n° 8000	n° 5000	n° 5000	n° 4000 *	n° 4000 *
USE FREQUENCY	SUPER INTENSIVE	SUPER INTENSIVE	SUPER INTENSIVE	SUPER INTENSIVE	SUPER INTENSIVE
GRADE OF PROTECTION	IP54	IP54	IP54	IP54	IP54
OPERATING TEMPERATURE	\downarrow -20°C \uparrow +55°C	\downarrow -20°C \uparrow +55°C	\downarrow -20°C \uparrow +55°C	\downarrow -20°C \uparrow +55°C	\downarrow -20°C \uparrow +55°C
ACCESSORIES POWER SUPPLY	24V $\overline{=}$	24V $\overline{=}$	24V $\overline{=}$	24V $\overline{=}$	24V $\overline{=}$
BOOM	up to 3 m	up to 4 m	up to 4 m	up to 6 m *	up to 6 m *
EMERGENCY BATTERY	AVAILABLE (OPTIONAL)	AVAILABLE (OPTIONAL)	AVAILABLE (OPTIONAL)	AVAILABLE (OPTIONAL)	AVAILABLE (OPTIONAL)
RELEASE SYSTEM	key with European cylinder	key with European cylinder	key with European cylinder	key with European cylinder	key with European cylinder
SOUND PRESSURE DURING USE	<70 dB(A)	<70 dB(A)	<70 dB(A)	<70 dB(A)	<70 dB(A)
CONTROL UNIT (INTEGRATED) 36V dc	CTRL/P	CTRL	CTRL	CTRL	CTRL
FORCE TO BE APPLIED ON THE MECHANICAL	<1,6Nm	<1,6Nm	<1,6Nm	<1,6Nm	<1,6Nm

* ATTENTION: In case of PARTICULARLY WINDY ZONES and/or SUPER INTENSIVE with BA/91/6 with mounted accessories (ex. rack, mobile support, magnet) or BA/91/6 without mounted accessories OVER 500 CYCLES PER DAY USE JNT/BA/91 joint (see fig. 9).

** Internal test verified at nominal values with maximum boom size at an ambient temperature of +25°C. The value shown is NOT the maximum value

10 TYPICAL INSTALLATION

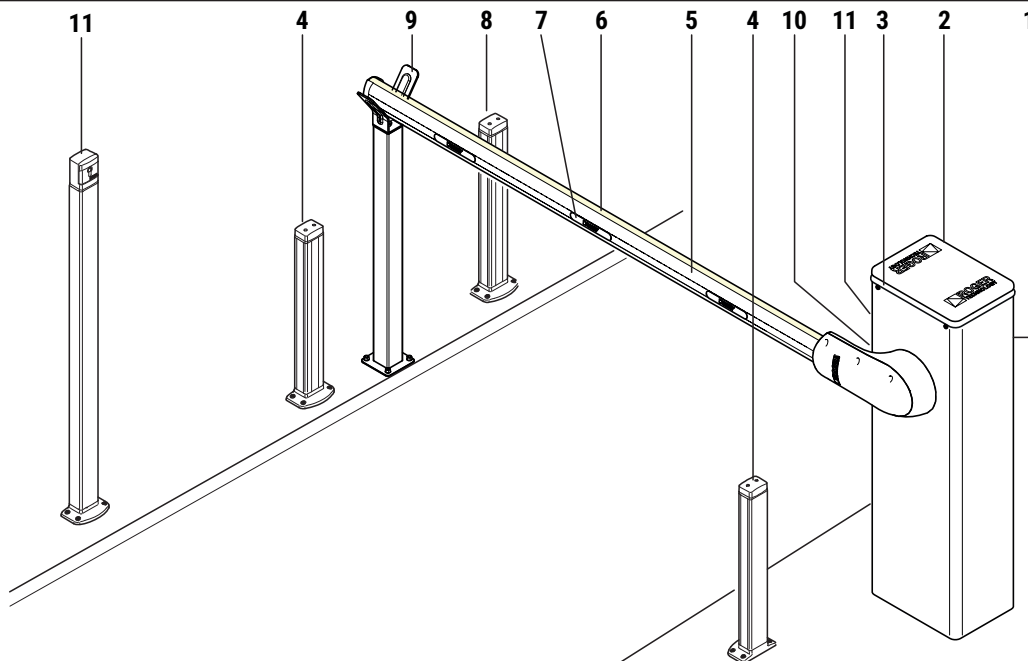

1	Automatic Barrier BIONIK
2	Integrated control unit
3	Flashing lights
4	External Photocell
5	Boom with shockproof rubber
6	Strip led

7	Reflective sticker
8	Internal photocell
9	Boom's Fixed support for boom
10	Release system
11	Key or keypad release switch

11 REFERENCES AND ACCESSORIES

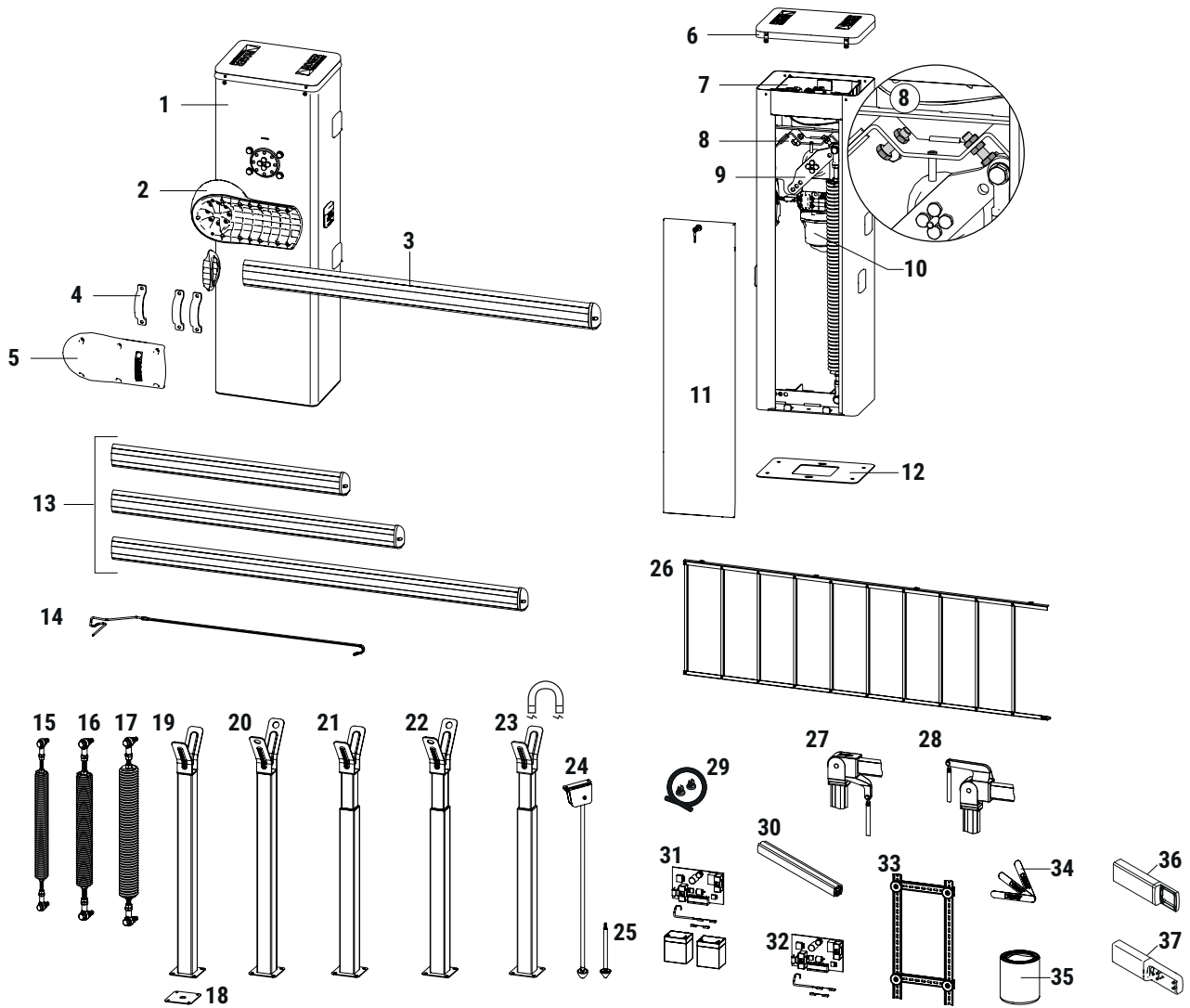

Code	Description
1	Carbon steel barrier assembly cabinet with anti-corrosion treatment, painted
2	Aluminium boom support base, die-cast, with anti-corrosion treatment, painted
3	Extruded aluminium boom, painted white
4	Galvanized steel omega support for securing the boom
5	Aluminium boom fixing cover, die-cast, with anti-corrosion treatment, painted
6	Head in die-cast aluminium with anti-corrosion treatment and painted, complete with diffuser in transparent polycarbonate and BI/BLED/6 led lights
7	CTRL/P CTRL Digital control unit for BI/001/PE Digital control unit for BI/004 and BI/006
8	Mechanical stop in opening and closing
9	Galvanized steel springs fixing arm
10	Geared motor complete with brushless motor and absolute encoder
11	Corrosion-resistant steel closing door, with anti-corrosion treatment, painted
12	KT230 Galvanised foundation plate for securing the barrier
13	BA/91/3 BA/91/4 BA/91/6 Elliptical boom up to 3 metres made of aluminium, painted white, with slot cover profiles and shockproof rubber Elliptical boom up to 4 metres made of aluminium, painted white, with slot cover profiles and shockproof rubber Elliptical boom up to 6 metres made of aluminium, painted white, with slot cover profiles and shockproof rubber
14	ALED/4C ALED/6C Strip LED 4 metres with connections cable Strip LED 6 metres with connections cable
15	SP/72/01 Ø72 spring for boom of up to 4 metres
16	SP/83/01 Ø83 spring for boom of up to 6 metres

Code	Description
17	SP/85/01 Ø85 spring for boom of up to 6 metres
18	KT231 Fixed support foundation plate
19	BAFS/01 Fixed support with rubber, NOT-adjustable
20	BAFS/03 Fixed support with rubber, NOT-adjustable, with provision of a bolt
21	BAFS/02 Fixed support with rubber, adjustable, telescopic
22	BAFS/04 Fixed support with rubber, adjustable, telescopic, with provision of a bolt
23	BAFS/05 Fixed end rest with rubber, adjustable, telescopic with rubber buffer and integrated magnet
24	BAMS/01 Mobile support for boom
25	BAMS/01/EXT Extension for mobile support
26	BARK/02 Painted aluminium rack in 2 metres modules
27	SND/BA/91/DW Joint with 90° pivot point with lower tie-rod
28	SND/BA/91/UP Joint with 90° pivot point with upper tie-rod
29	KT242 Magnetic cable passage kit
30	JNT/BA/91 Internal connection joint made of anodized aluminium
31	BI/BAT/KIT Emergency battery kit complete with battery charger and wiring (optional)
32	BI/BCHP Battery charge board complete with wiring (optional)
33	KT239 DIN Bar
34	R99/BASB20 Pack of N. 20 reflective adhesive strips for the boom
35	RS/GR1/100 Lithium grease (EP LITIO)
36	CRA/BAR Column for G90 photocells, for spaced installation on barrier cabinet (+23 cm)
37	CRA/BAR/M90 Column for M90 photocells, for spaced installation on barrier cabinet (+23 cm)

ATTENTION! For the correct installation and use of the accessories refer to the respective instruction manuals.

12 INSTALLATION

12.1 Preliminary checks

- Check that the material received is in good condition and suitable for the application.
- Check that the operating limits of the product are not exceeded.
- Check that the site chosen for installation meets the overall space requirements of the product and that there are no obstacles hindering open or close manoeuvres.
- Check the concrete base for the barrier installation. The base must be cast in accordance with proper working practices, perfectly level and clean.

12.2 Installing base plate

The illustrations herein are indicative only. The space necessary for fastening the automation system and the accessories may vary depending on the overall dimensions of the installation. The installer is responsible for determining the most suitable solution.

- Excavate a foundation pit measuring 1m x 1m x 0.4 m and fill with concrete reinforced with steel mesh.
- Fasten the 4 anchor ties to the plate (fig. 1). **N.B.:** the bottom nut must be tightened to the end of the thread on the screw so that the length Z is at least 40 mm.
- Sink the base plate with the anchors in the centre of the foundation pit, so that the surface is flush with the concrete and perfectly level. The corrugated cable conduits must protrude by a few centimetres from the centre of the plate.
- **Installation on existing surfaces.** Place the base plate on the surface and trace the positions of the fastener points. Drill the surface and fit 4 expansion anchor bolts (purchased separately).

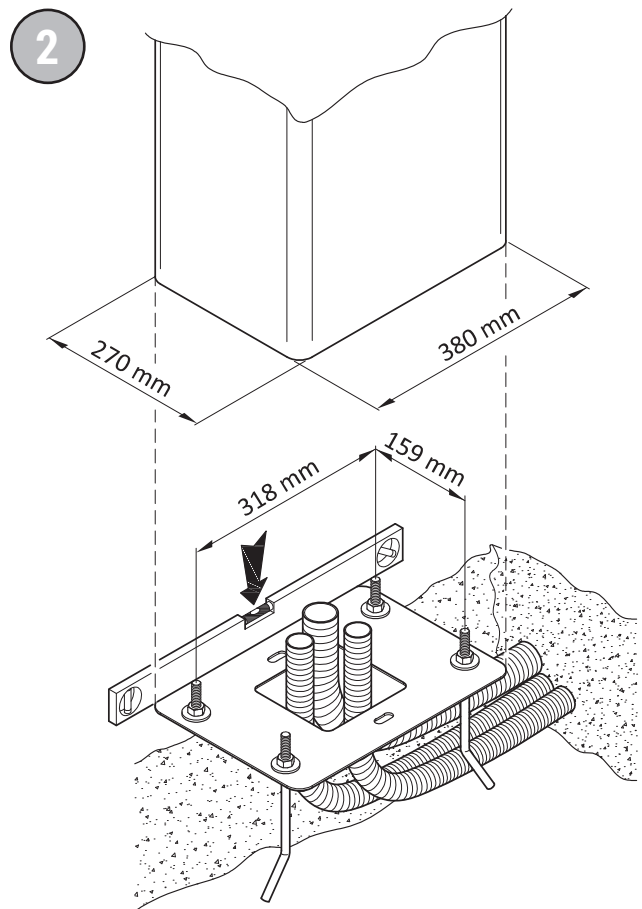
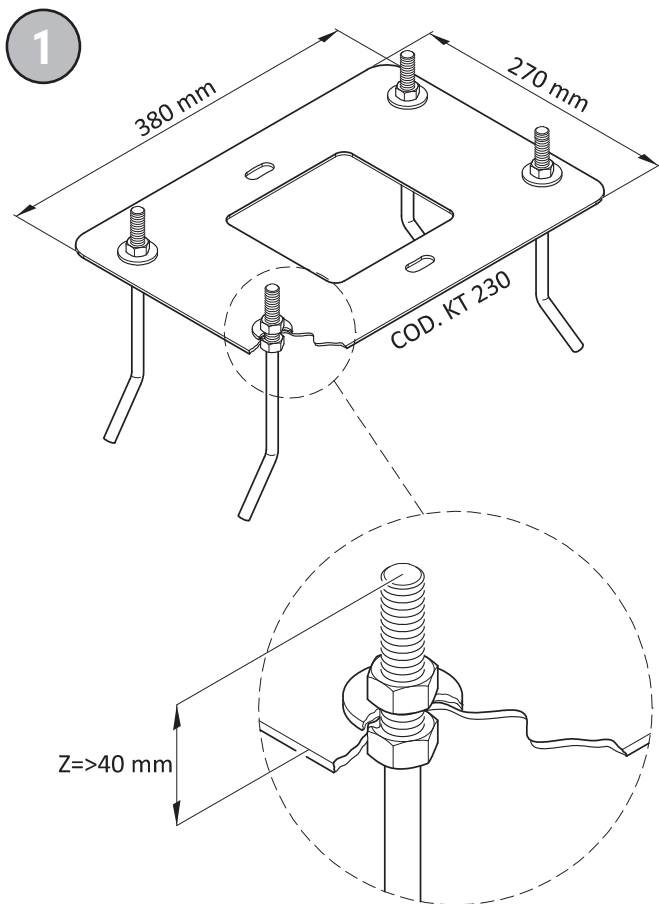

12.3 Installing the barrier

N.B.: the barrier is configured by default for installation on the right hand side (viewed from inspection hatch side).

- Undo and remove the washers and nuts from the anchors on the base plate (fig. 3).
- Open the inspection hatch, turning the key clockwise by 90° (fig. 4).
- Remove the inspection hatch (fig. 5).
- Place the cabinet on the plate. The anchors on the base plate must fit through the four slots.
- Fit the washers and nuts removed previously. Move the cabinet as necessary in the slots to adjust the position of the barrier correctly. Tighten the nuts securely (fig. 6).

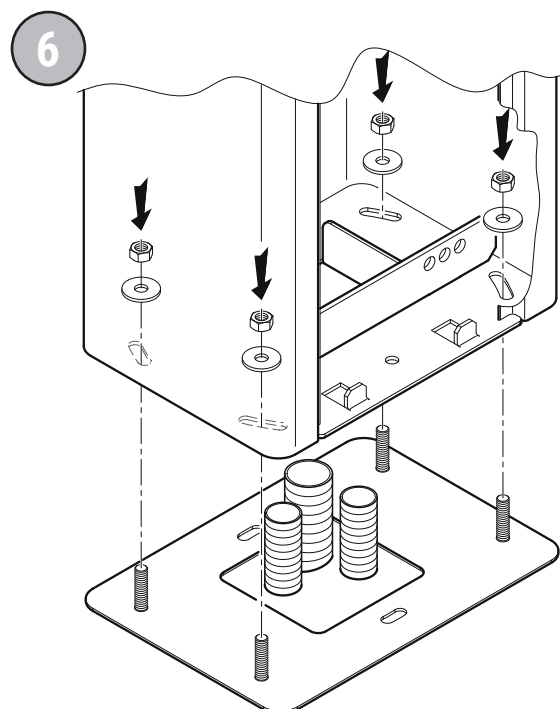
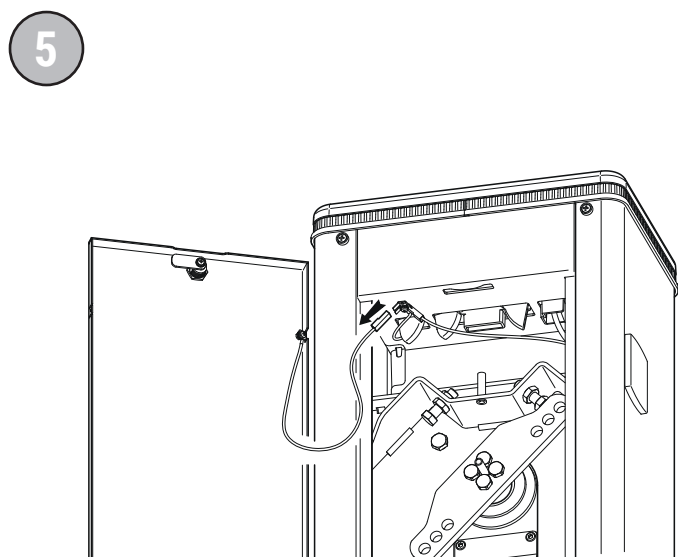
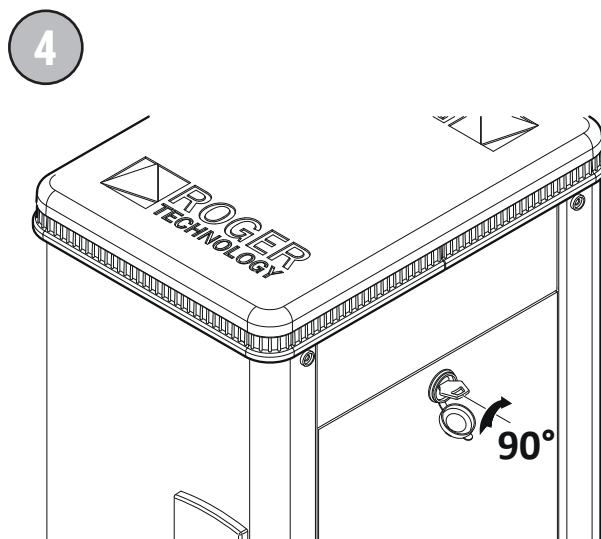
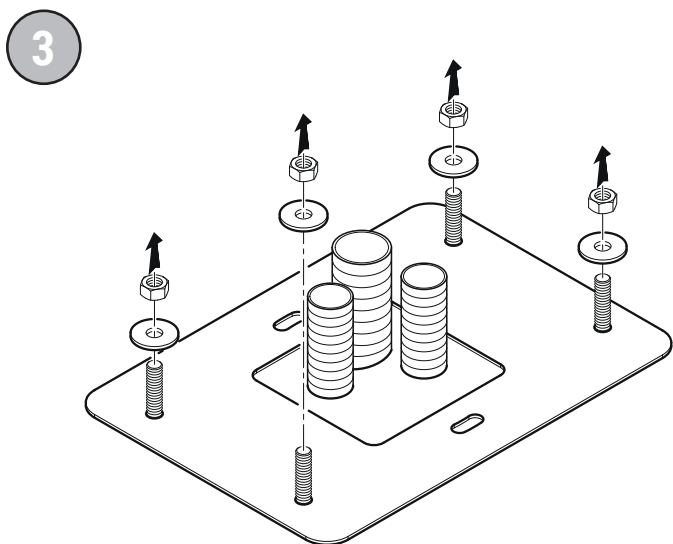

12.4 Selecting direction of aperture

i BIONIK barriers are configured by default for installation on the right hand side (seen from the inspection hatch side).

! Whenever corrective actions are carried out, pay the utmost attention when releasing, locking or moving the internal mechanical parts. These operations could be hazardous for the installer.

For left hand installations:

- Unlock the barrier (see chapter 22).
- Turn the linkage lever as shown in fig. 8.
- Move the mechanical stop.
- Lock the barrier (see chapter 22).

7

INSTALLATION ON THE LEFT

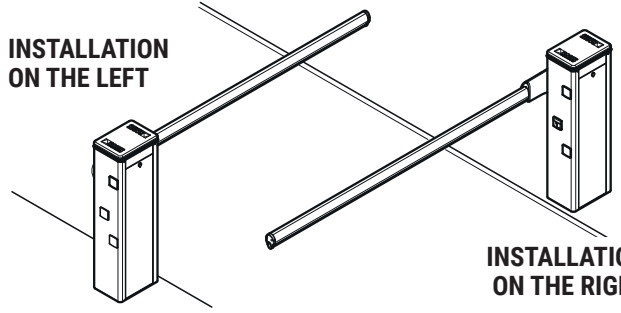

INSTALLATION ON THE RIGHT

8

BARRIER INSTALLED ON THE RIGHT (seen from the inspection hatch side) AND THE BOOM OPENING/CLOSURE GATE ON THE LEFT

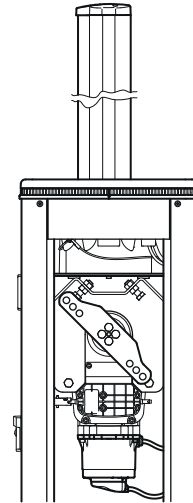
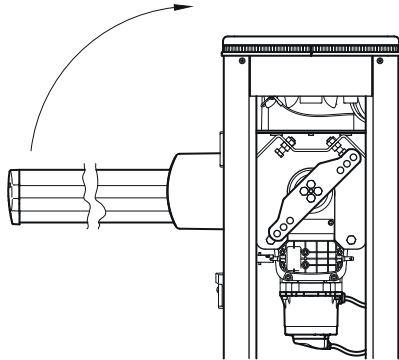

BARRIER INSTALLED ON THE LEFT (seen from the inspection hatch side) AND THE BOOM OPENING/CLOSURE GATE ON THE RIGHT

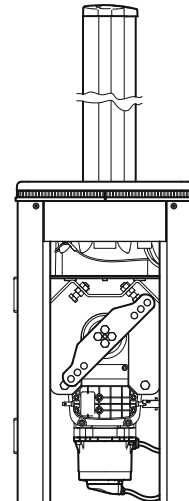
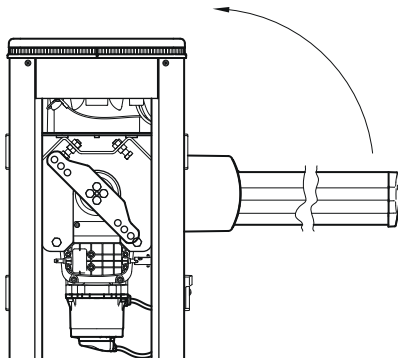

12.5 Installing the boom (fig. 9)

- Unlock the barrier (see chapter 22).
- Turn the linkage lever into the position necessary for installing the boom horizontally.
- Lock the barrier.
- Fasten the boom mounting base [A] to the flange [C] with the zinc plated M10x35 screws [B], tightening securely.

In case of installation with JNT/BA/91:

- Insert the full length of the joint [M2] into the boom.
- Secure the boom and M2 joint with the 10 supplied self-drilling screws [N], 5 above and 5 below, along the axis of the boom at 60 mm intervals.
- Insert the boom [D] in its seat.
- Fasten the mounting brackets [F] to the boom mounting base [A] with the zinc plated M10x20 screws [E], tightening securely.
- Fit the aluminium cover [G], and fasten with the stainless steel M8 screws [H].

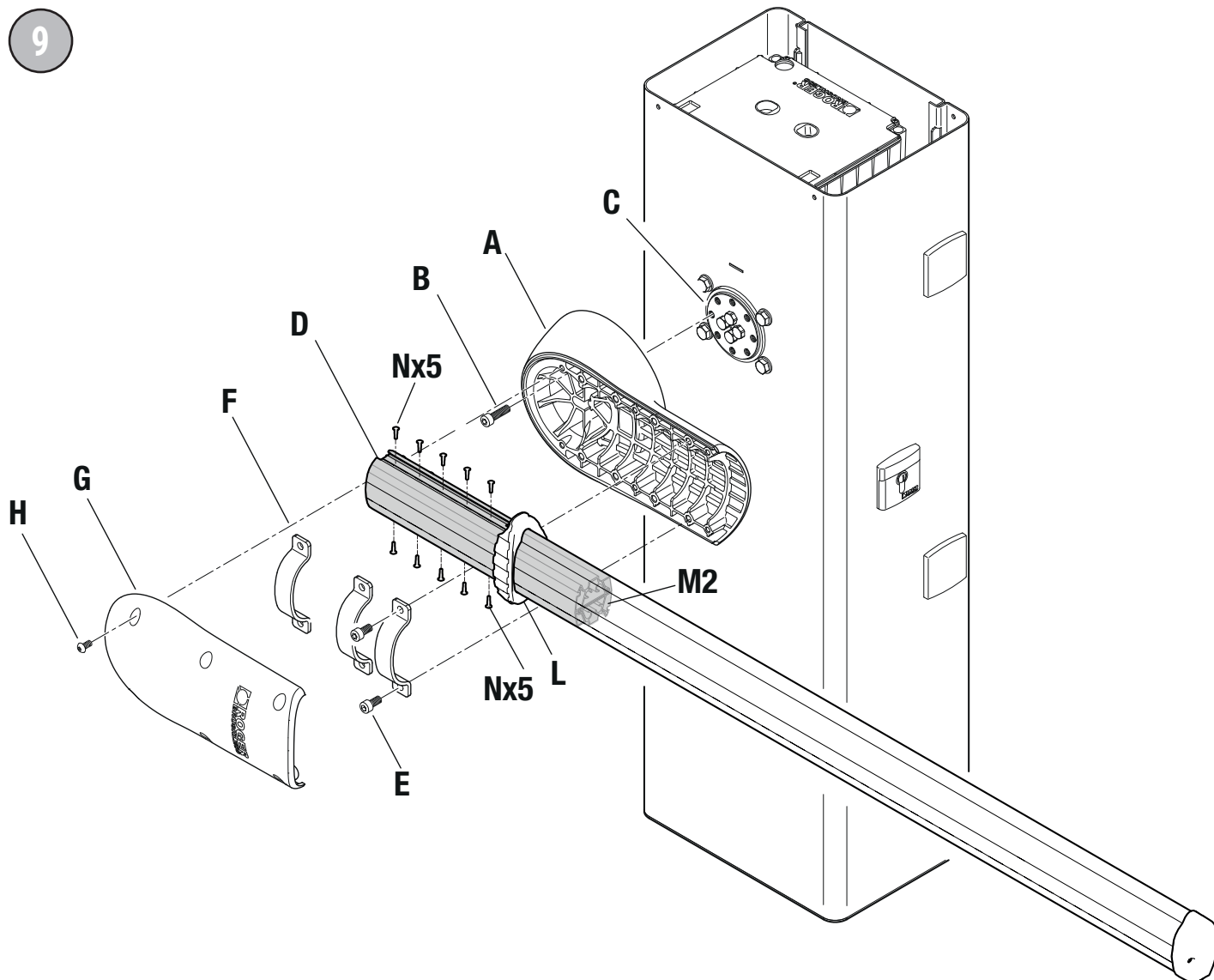

13 INSTALLING AND ADJUSTING THE SPRING

1. Unlock the barrier (see chapter 22) and move the boom into the completely open vertical position.
2. Select the most suitable spring (see tables in paragraph 12.1).
3. Use the screws included to fasten the spring to the linkage lever (fig. 10) on the correct side for the direction of aperture and in using the most appropriate mounting hole to allow the barrier to function correctly.
4. The springs are colour coded for identification. **NOTE:** The coloured part of the spring must always be at the top.
 - 72 mm diameter springs (SP/72/01) are red;
 - 83 mm diameter springs (SP/83/01) are yellow;
 - 85 mm diameter springs (SP/85/01) are grey.

⚠ IMPORTANT: Using the holes furthest from the centre of the linkage lever (A-1) will result in a higher spring tension when the barrier is operating. Using the holes closest to the centre of the linkage lever (C-3) will result in a lower spring tension (see paragraph 12.2).

5. Secure the springs to the fixed structure (fig. 11) by fastening to the steel cross boom of the barrier using the screws included.
6. Lubricate the pivot points with lithium based grease (EP LITIO) (fig. 12). A 100 g tub of lithium grease may be ordered separately with article code RS/GR1/100.

EN

13.1 Spring balancing (fig.13)

1. Lift the boom manually to an angle of 45° and let go. If the boom rises, reduce the spring tension. If the boom drops, increase the spring tension.
 2. To adjust the spring tension, loosen the nuts [A]. Turning [B] the spring clockwise the tension is reduced, turning anticlockwise the tension is increased.
 3. Once the spring tension is correct, tighten the lock nuts securely.
- In order to protect the spring from moisture and internal condensation, it is good practice to brush the spring with a thin layer of grease, which will prevent rusting.
 - It is good practice to silicon the cable passage hole at the base of the barrier.

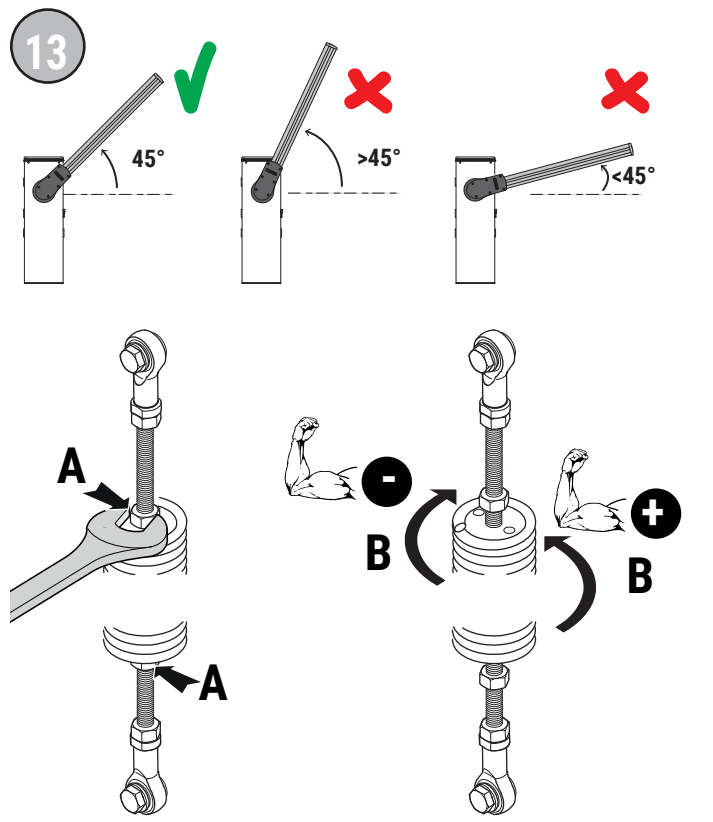
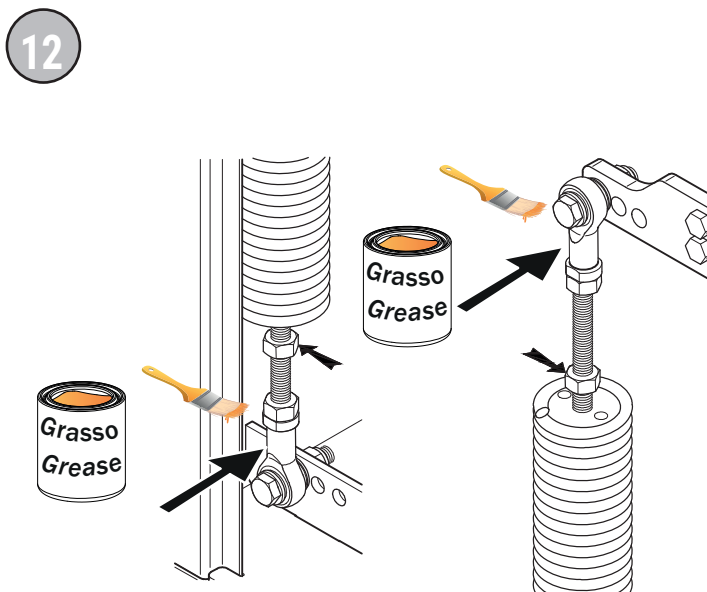
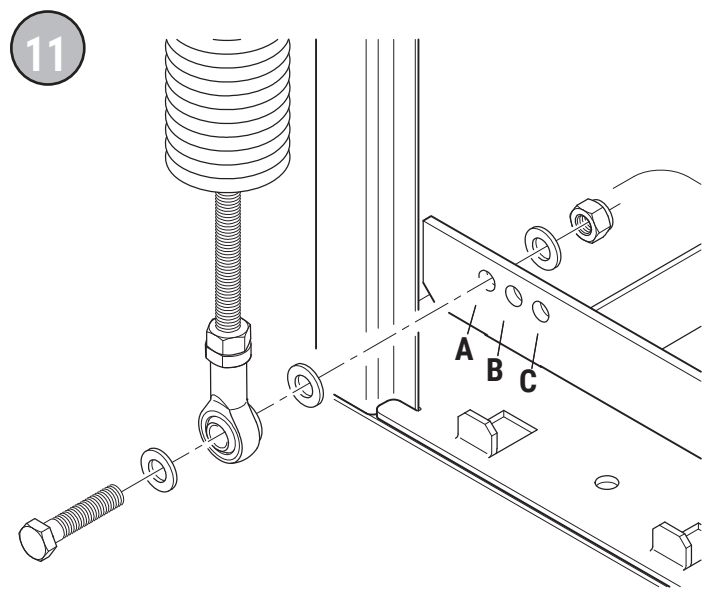
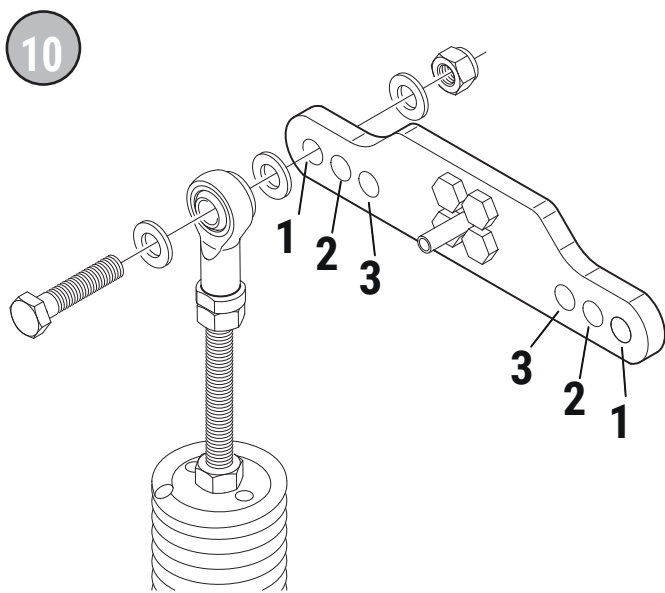

13.2 Spring tensioning

BARRIER INSTALLED ON THE RIGHT - seen from the inspection hatch side (Factory configuration)

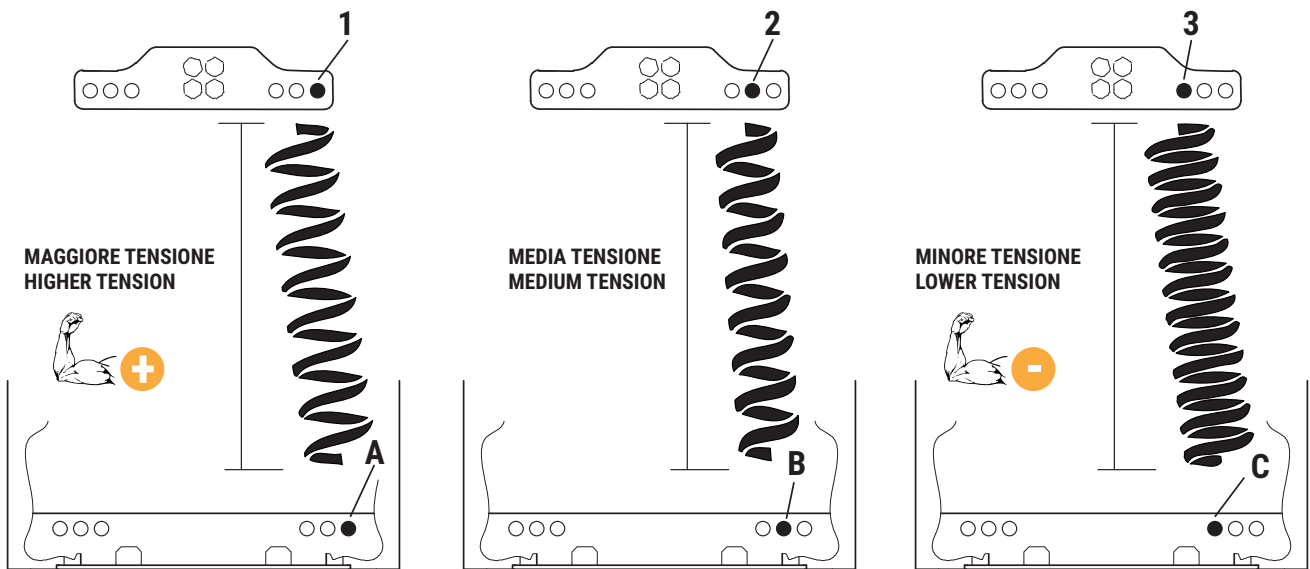

BARRIER INSTALLED ON THE LEFT - seen from the inspection hatch side

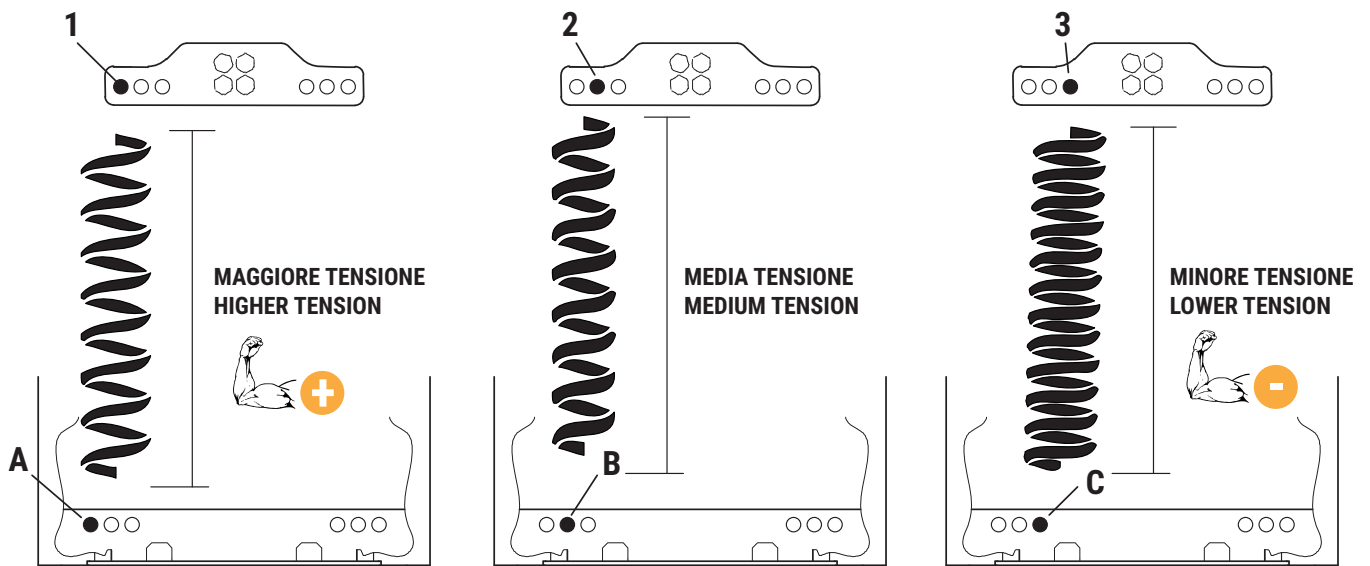

APPROXIMATE EXAMPLES

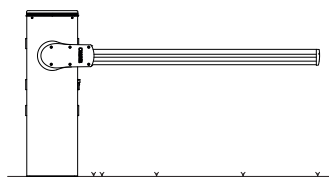

C-3

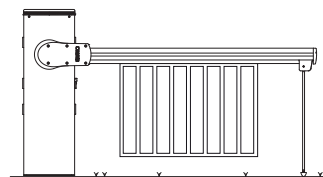









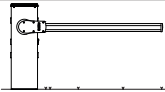
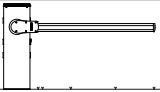
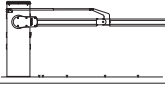
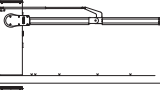
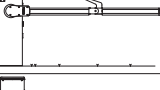

A-1

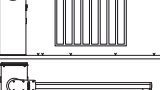
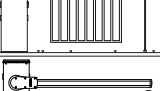
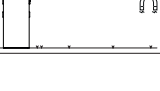

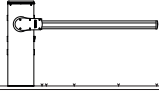
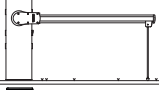
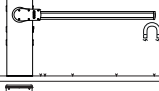
Each installation is unique and the tension of the springs must be checked and tested.

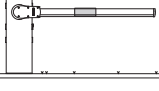
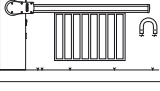
13.3 Spring selection

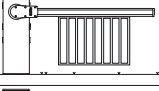
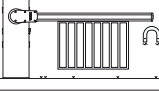
i For choosing the most suitable configuration, the booms are understood as complete with shock-resistant rubber and LED strips.

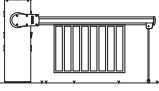
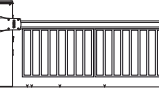
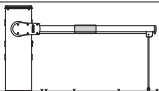
		BI/001PE with boom up to 3 m	BI/004HP with boom up to 4 m	BI/006 with boom up to 6 m		
EN	SP/72/01  Rosso/Red			/		
						
		/				
						
						
						
						
						
				 The adjustable fixed end rest with integrated magnet BAFS/05 must be used.		
SP/83/01  Giallo/Yellow	/	/	/			
						
					 The adjustable fixed end rest with integrated magnet BAFS/05 must be used.	
						
					 The adjustable fixed end rest with integrated magnet BAFS/05 must be used.	
SP/85/01  Grigio/Grey	/	/	/			
					 The adjustable fixed end rest with integrated magnet BAFS/05 must be used.	
						
						
						

 **WARNING!** For booms of 4 m or more, it is mandatory to use the BAFS fixed end rest or the BAMS hinged end rest.

 **WARNING!** Images are purely indicative, for correct installation and use of the accessories refer to the respective instruction manuals.

14 ADJUSTING THE MECHANICAL STOP

- Figure 14 shows the mechanical stop on a barrier installed on the left hand side. For barriers installed on the right, perform the mirror images of the procedures illustrated.
- Unlock the barrier (see chapter 22).
- Set the completely open **AP** and completely closed **CH** positions by adjusting the relative mechanical stops.
- Lock the barrier (see chapter 22).

14

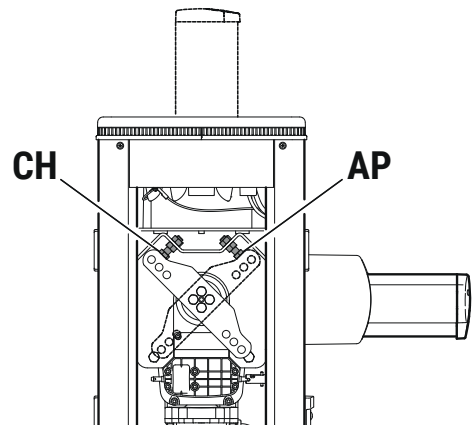

15 INSTALLING THE LOCK RELEASE SYSTEM

The lock release system is already installed in the factory on one of the two side of the barrier.

If it is necessary to install the system on the opposite side (compared to springs):

- Open the inspection hatch.
 - Remove the screws fastening the plastic cover [A].
 - Remove the escutcheon plate [B] of the lock release system, prising the lateral clips open to detach.
 - Undo the two self-tapping screws [C] and remove the aluminium front panel [D].
 - Undo the four M5 nuts [E].
 - Push the steel connector [F] outwards to compress the spring and rotate by 45°.
 - Detach the lock release system and install on the opposite side, taking care not to damage the safety cable.
- N.B.:** two coloured caps (red and green) are fitted to check that the lock release system is installed correctly, regardless of which side it is fitted on. When the barrier is locked, the green cap must face towards the inspection hatch (installer view). If not, the lock release system is installed incorrectly.
- Tighten the nuts [E].
 - Fit the aluminium front panel [D] and fasten with the screws [C].
 - Fasten the escutcheon plate [B] on the lock release system.
 - Fit the plastic cover [A] on the opposite side.

15

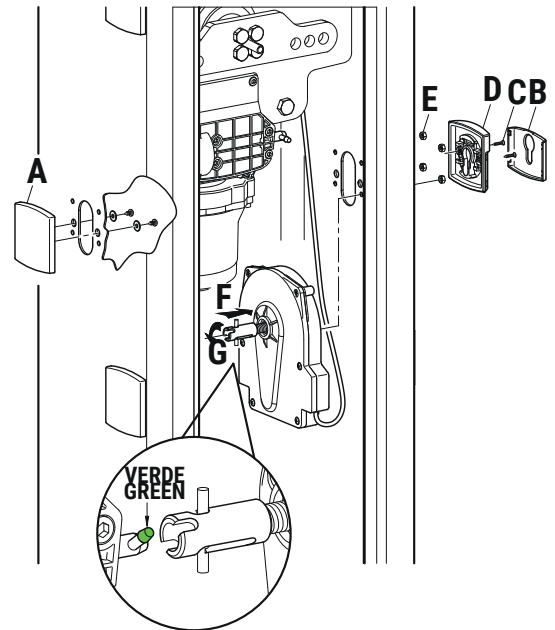

16 CONNECTING PHOTOCELLS

G90/F4ES photocells may be installed on both sides of the barrier at two different heights: (50 cm or 100 cm).

- Disconnect from mains electricity and from battery power (if applicable).
- Open the inspection hatch, turning the key clockwise by 90°.
- Undo the four screws fastening the head.
- Remove the head after disconnecting the flashing light cables.
- Open the cover of the **CTRL** or **CTRL/P** control unit.
- Undo the two screws fastening the plastic cover of the photocell housing from the inside.
- Fasten the **G90/F4ES** photocells to the barrier.
- Route the connector cables upwards, taking care not to interfere with the movements of the automation system, and push them through one of the openings on the control unit box.
- Connect the photocells cables to the specific terminals as indicated in the installation manual for the **CTRL** or **CTRL/P** controller.
- See the **CTRL** or **CTRL/P** control unit manual for instructions on setting the photocells.
- Close the control unit cover correctly, ensuring that it is watertight.
- Refit the barrier head.
- Close the inspection hatch, turning the key anticlockwise by 90°.
- Tighten the four screws to the head.

16

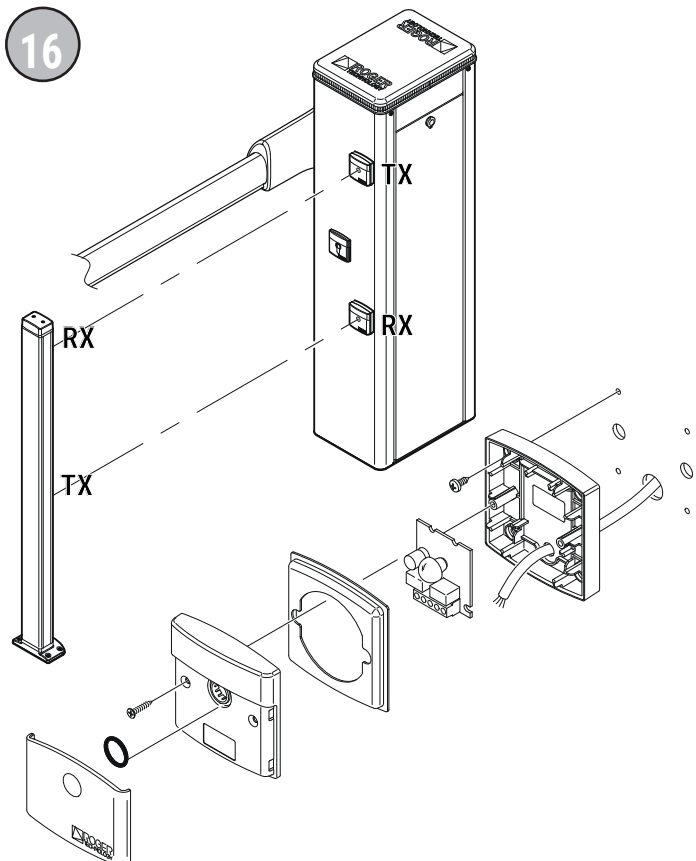

17 ELECTRICAL CONNECTIONS

17

All electrical connections must be made with the unit disconnected from mains power and, if applicable, battery power.

See the **CTRL** or **CTRL/P** controller manual for instructions on making connections and programming.

Before connecting to electrical power, ensure that the mains power specifications on the identification plate match the mains power supply used.

A switch or an omnipolar cut-off switch with a contact opening of at least 3 mm must be installed on the mains power line.

Ensure that an adequate residual current circuit breaker and a suitable overcurrent cut-out are installed ahead of the electrical installation.

Use a 3x2.5 mm² double insulated cable for the mains power line.

Feed the cable on the left hand side of the barrier through the openings on the left hand side of the controller casing and connect it to the terminals L (brown), N (blue) and \oplus (yellow/green) inside the automation unit.

Fasten the power cable with the cable grips included.

At least 50 mm of the connector cable conduit must protrude from the holes in the base plate and into the automation unit.

Ensure that there are no sharp edges which could damage the power cable.

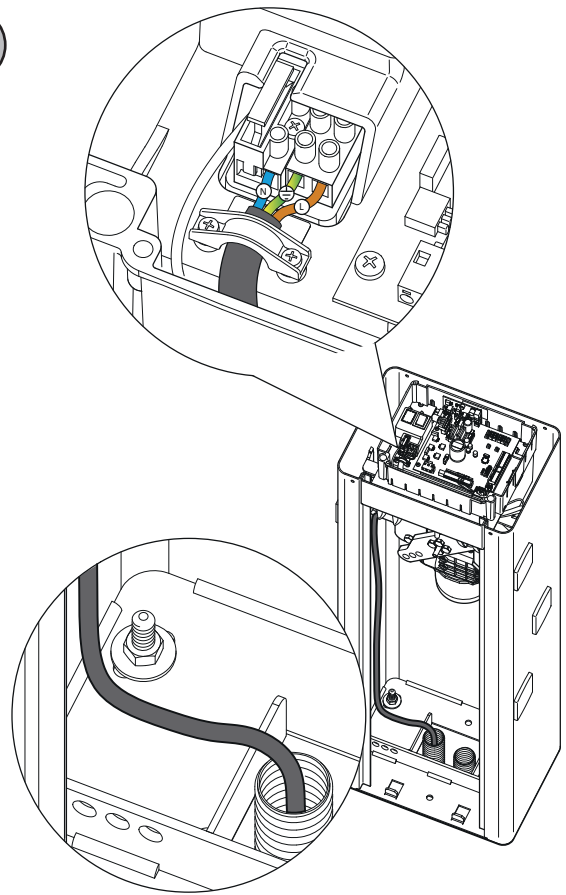

18 INSTALLING THE BATTERY KIT (OPTIONAL)

1. Disconnect the mains power.
2. Unscrew the four screws **[Z]** and remove the head **[A]** (if applicable).
3. Lift the cable grommet **[B]** and disconnect the connector **[C]**.
4. Open the transparent control unit cover **[D]**.
5. Switch the control unit switch to the OFF position **[E]**.
6. Lift the control unit and insert the batteries in their housing **[F]**.
7. Connect the red, black and blue wires to the batteries (see detailed view)
8. Connect the batteries to the **+BATTERY** terminal (red wire) and **-BATTERY** terminal (black wire).
9. Insert the battery charge board BI/BCHP in the plug-in connector **[G]**.
10. Reposition the control unit.
11. Switch the control unit switch to the ON position **[E]**.
12. Reposition the transparent control unit cover **[D]**.
13. Reconnect the connector **[C]** and close the cable grommet **[B]**.
14. Close the head **[A]** and tighten the four front screws **[Z]**.
15. Reconnect the mains power.

18

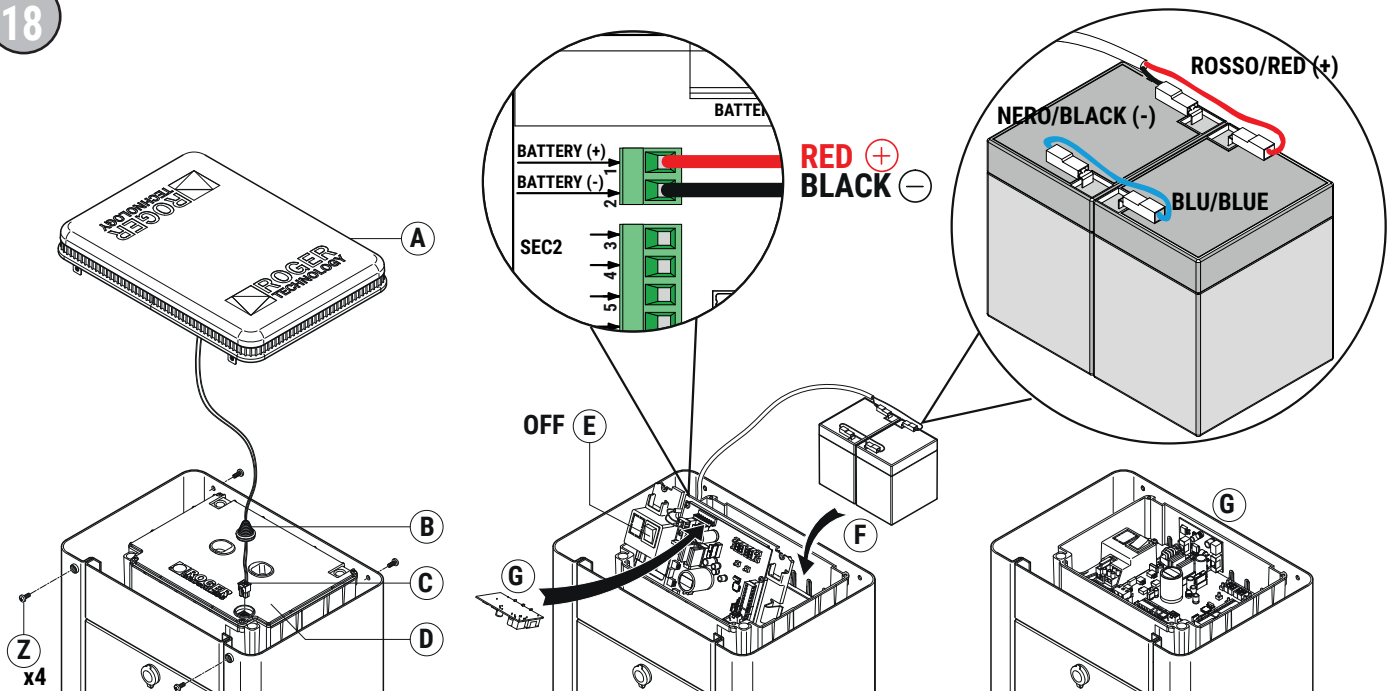

19 INSTALLING THE BI/BLED/6 LED FLASHING LIGHT (fig. 19)

The **BI/BLED/6** flashing lamp unit is factory supplied already pre-installed in the head **[A]**, packaged separately inside the BIONIK package.

1. Insert the connector **[B]** in the LIGHT terminal of the control unit.
2. Refer to the control unit manual for the flashing lamp unit settings.
3. Fasten the cable grommet **[C]**, making sure it is positioned correctly.
4. Position the head **[A]** on the barrier.
5. Tighten the four fastening screws **[Z]**.

In case of replacement:

1. Disconnect the mains and battery power supplies (if applicable).
2. Unscrew the four screws **[Z]** that fasten the head **[A]** to the barrier.
3. Lift the cable grommet **[C]**.
4. Disconnect the connector **[B]**.
5. Remove and overturn the head **[A]**.
6. Remove the **BI/BLED/6** flashing lamp unit **[D]** from the diffuser.
7. Insert the new LED circuit in the diffuser, paying attention to the installation direction (fig. 20).
8. Insert the connector **[B]** in the LIGHT terminal of the control unit.
9. Refer to the control unit manual for the flashing lamp unit settings.
10. Fasten the cable grommet **[C]**, making sure it is positioned correctly.
11. Reposition the head **[A]** on the barrier.
12. Tighten the four fastening screws **[Z]**.
13. Reconnect the mains and battery power supplies (if applicable).

19

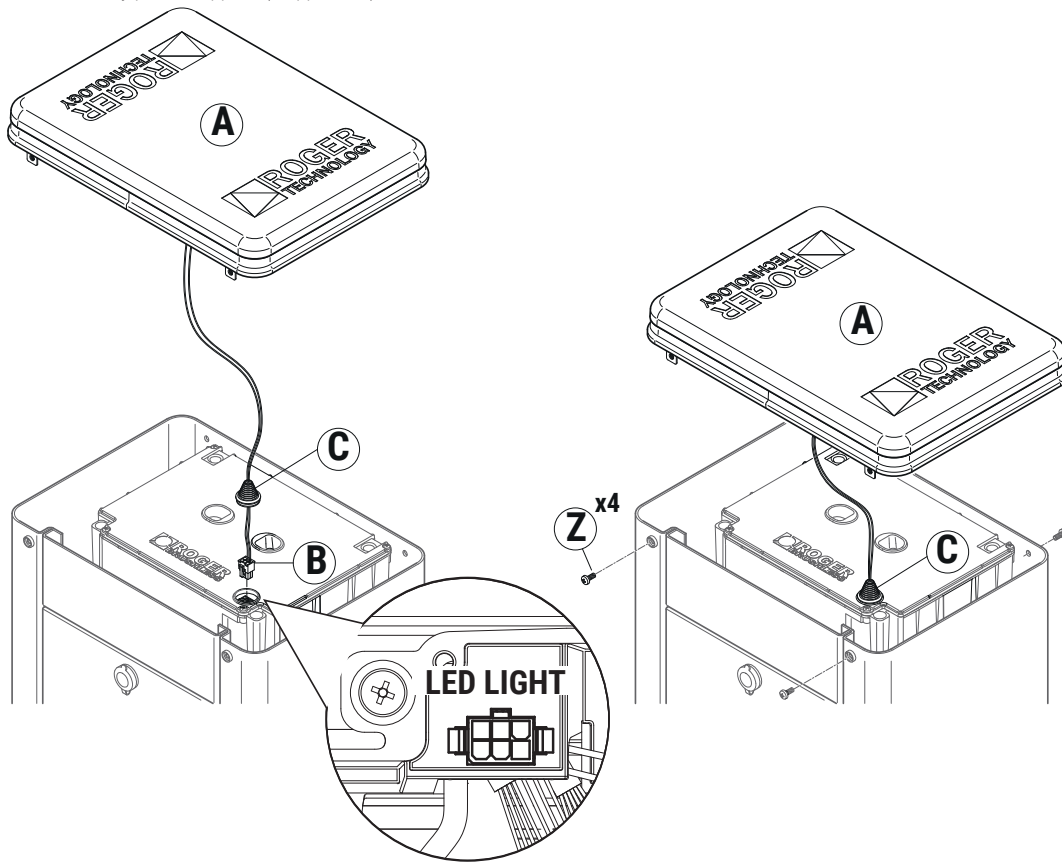

20

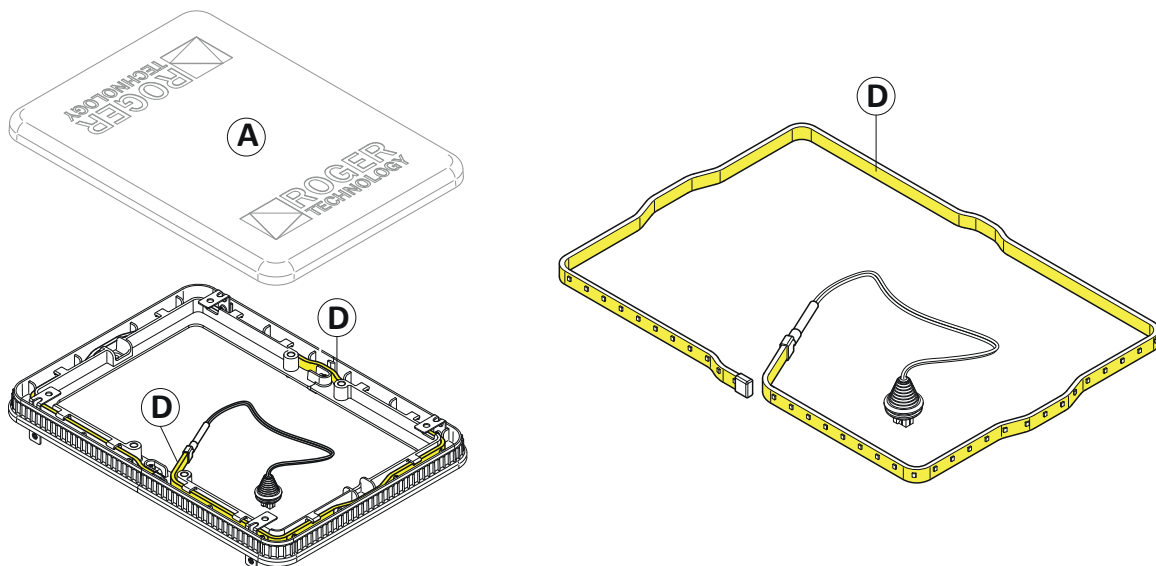

20 MAINTENANCE

N.B.: Only use original spare parts when repairing or replacing products. The installer must provide the user with complete instruction for using the motorised door or gate in automatic, manual and emergency modes, and must hand the operating instructions to the user of the installation upon completion. The installer must compile the maintenance log book, in which all scheduled and un-scheduled maintenance operations performed must be indicated.

- The installation must be subject to regular maintenance. We recommend servicing at least once every 6 months.
- Disconnect from mains electricity and from battery power (if applicable) to avoid the risk of accident or injury.
- Check the tightness of all the fastener screws and nuts.
- Clean the photocell lenses with a cloth moistened slightly with water. Do not use solvents or other chemical products, as these may damage the electronic components.
- Clean and lubricate the pivot points with lithium based grease (EP LITIO).
- Check the electrical connections.
- Check that the manual lock release system works.
- Check that the boom is balanced correctly as indicated in chapter 12.
- Check that there are now plants within the radius of action of the boom which could interfere with the photocells or with the movements of the boom itself.

Reconnect to mains power.

- Check that the safety devices and all the control functions work correctly.
- Check that the obstacle detection function works correctly.
- Check that there is no risk of the boom accidentally lifting persons or objects.
- Check that the force limiting function prevent potentially dangerous situations in compliance with the standard EN 12445.

21 DISPOSAL



This product may only be uninstalled by qualified technical personnel, following suitable procedures for removing the product correctly and safely. This product consists of numerous different materials. Some of these materials may be recycled, while others must be disposed of correctly at the specific recycling or waste management facilities indicated by local legislation applicable for this category of product.

Do not dispose of this product as domestic refuse.

Observe local legislation for differentiated refuse collection, or hand the product over to the vendor when purchasing an equivalent new product.

Local legislation may envisage severe fines for the incorrect disposal of this product.

Warning! some parts of this product may contain substances that are harmful to the environment or dangerous and which may cause damage to the environment or health risks if disposed of incorrectly.

22 ADDITIONAL INFORMATION AND CONTACT

ROGER TECHNOLOGY is the exclusive proprietor holder of all rights regarding this publication.

ROGER TECHNOLOGY reserves the right to implement any modifications without prior notification. Copying, scanning or any alterations to this document are prohibited without express prior authorised from by ROGER TECHNOLOGY.

ROGER TECHNOLOGY CUSTOMER SERVICE:

business hours: Monday to Friday
08:00 to 12:00 - 13:30 to 17:30

Telephone no: +39 041 5937023
E-mail: service@rogertechnology.it
Skype: service_rogertechnology

23 RELEASE AND LOCK PROCEDURE

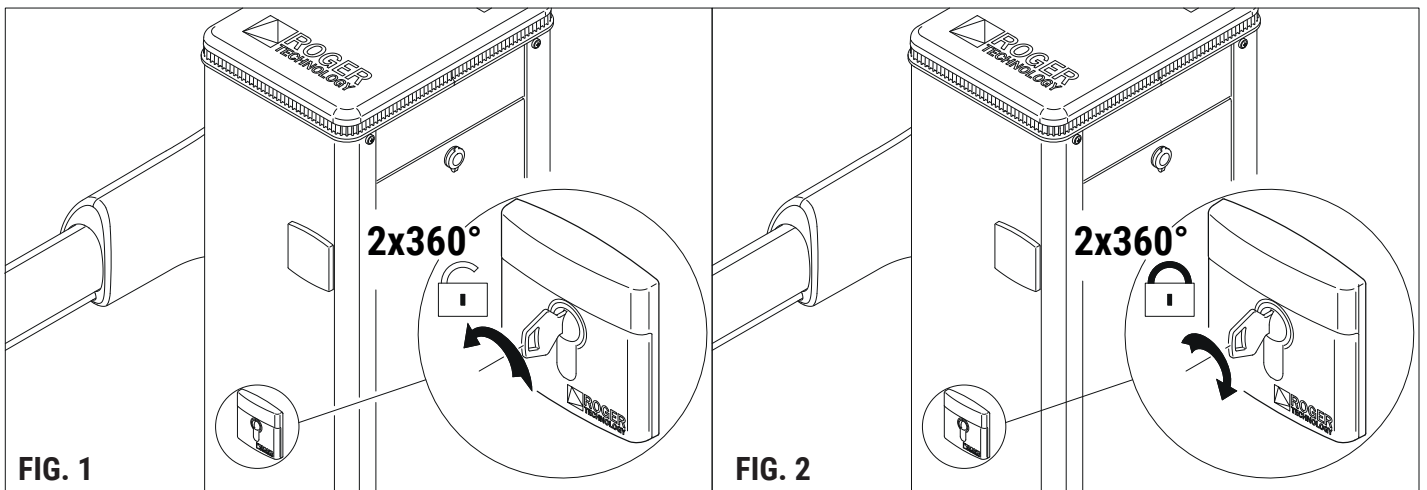

⚠ Whenever corrective actions are carried out, pay the utmost attention when releasing, locking or moving the internal mechanical parts. These operations could be hazardous for the installer.

In some situations, such as in the event of a power outage or scheduled or extraordinary maintenance, it is necessary to release the automation. The operation of the release of the automation must be carried out when the boom is stopped in the closed position (horizontal). Moreover, ensure that at the time of release, no person, animal, item or vehicle is passing by or stopped within range of automation.

RELEASE AND MANUAL OPERATION

Insert the key included into the lock and turn it anticlockwise by 360° making 2 complete turns, as indicated in fig. 1. Move the boom manually.

RESTORING AUTOMATIC OPERATION

To lock the barrier again, turn the key clockwise by 360° making 2 complete turns, as indicated in fig. 2. Remove the key and give to the user.



Advanced Security Distribution Limited
sales@asdltd.ie +3530473 4550 www.asdltd.ie

