

* ALWAYS TEST THE UNIT ON SITE BEFORE INSTALLATION TO AVOID RESTOCKING FEES *

A CLOSER LOOK AT THE 4G ACCESS POINT

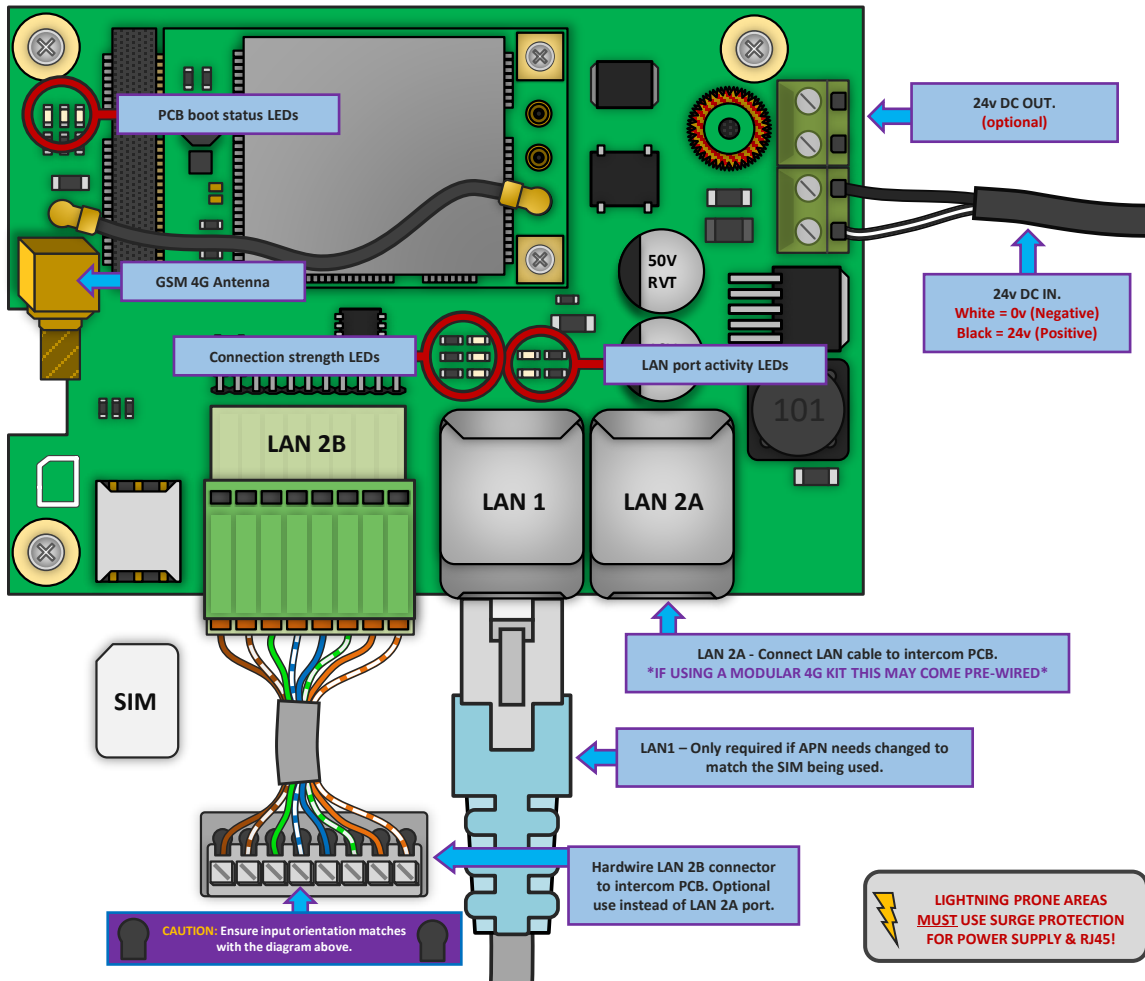

LIGHTNING PRONE AREAS MUST USE SURGE PROTECTION FOR POWER SUPPLY & RJ45!

SIM ORIENTATION

ALWAYS ensure that the system is switched **OFF** any time you are adding or removing the SIM card and also ensure that the orientation is correct before powering the router back on.

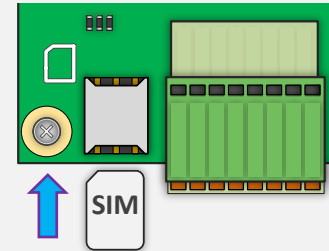

PCB BOOT STATUS LEDs

When the PCB has successfully booted up you should have activity on all 3 LEDs:

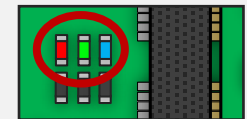

- RED:** Constant ON = **PCB Powered ON** | Constant OFF = **PCB Powered OFF**
- GREEN:** Steady Flash = **Connected to Network** | Constant OFF = **Not Connected**
- BLUE:** Steady Flash = **Standby Mode** | Constant OFF = **Booting / OFF**

DATA TRANSFER LEDs

The 2 LEDs behind LAN 1 Port will flash **GREEN** when you have connection activity.

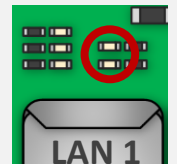

SIGNAL STRENGTH LEDs

The 3 LEDs behind LAN 1 Port will illuminate **WHITE**.

- Flashing = 3G signal
- Solid On = 4G signal

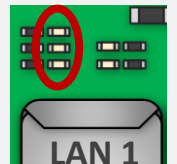

Praetorian Guard



NEW Gen of our Wi-Fi/4G Intercom Range.

- With an all **NEW APP!**
- Program PROX & Keypad codes from our app
- Callers can leave messages when unanswered
- Notify when gate is triggered
- Motion Sensor with auto record & notify
- HD Camera



- ATTENTION! -

Additional setup steps are required if using a different SIM that the Vodafone SIM that is provided with the unit. Please scan this QR code or search on our website for the 'How To Change APN Guide'.



EXTRA RESOURCES

<https://www.aesglobalonline.com/installer-resources>

* ALWAYS TEST THE UNIT ON SITE BEFORE INSTALLATION TO AVOID RESTOCKING FEES *

TROUBLESHOOTING

Symptoms caused	Problem/error	Solution
No LEDs on.	The unit will not power up.	Check power supply voltage at intercom is 23.4v DC or more. Cable length from PSU to intercom should be less than 25 feet and in 14 gauge for longer distances.
No green CPU light	The unit powers up but is not showing network reception or will not respond to SMS.	A. This means the unit is not able to detect the network for some reason. -Power off the unit, remove the SIM and check it in a mobile phone to verify it can make a call and has calling credit if it is a Pay As You Go SIM. -Disable any PIN code request if active on the SIM card. -Check the SIM is a standard voice capable SIM. If you are unsure, contact your SIM card provider to verify. -Check the reception is medium or good. Poor reception is not sufficient. -Power off, remove the SIM, use fine sand paper to lightly sand the SIM pads and contacts on the GSM unit, lightly bend the contacts upwards so that they make better contact with the SIM and try again. -Check antenna is connected and does not have too many sharp bends on the antenna cable. -Check the height of the antenna and make sure it is not inside a metal enclosure. - Check correct power cable size for cable length from PSU. Refer to manual for guidelines
All LED's are as expected but I do not have an internet connection	Unable to browse the internet or get intercom ONLINE	- Check the APN settings of the Router to ensure they match the SIM being used. - Check the SIM is active and has data by adding it into a mobile and searching the web.

WARRANTY

Please note, by installing this product, you are accepting the following warranty terms:

- The manufacturer's warranty is a "return to base" 2 year warranty from date of manufacture. This means that any suspected defective components or items are returned to the manufacturer's agent for investigation and diagnosis and returned at the cost of the customer.
- The warranty does not cover, nor is the manufacturer or agent responsible for any of the following whatsoever: Storm damage, lightning or surge damage, flooding, accidental damage, vandalism or deliberate damage, un-explained corrosion or unusually harsh environments, failure of telephone networks, future un-interoperability between the product and network providers which cause mal-function due to changes implemented by the phone providers after manufacture of the product, or that which is outside of control of the manufacturer (e.g. 2G, 3G switch off, removal or inability to obtain VOLTE service), and damage due to not proper installation.
- The manufacturer in no way accepts liability for any of the following incurred due to a product defect: Cost of attending site, inconveniences, labour rates, time lost, loss to or damage to property, security breaches, late payment clauses or breaches of any contracts between the installer and the client.
- This is a profession install product only. The product is a component of an overall system. Therefore, it is the responsibility of the installer to certify the safety and compliance of the overall finished system. As soon as this product is fixed to another item, or connected to another third-party device, then the product has been modified, and compliance with local regulations in the country of install is strictly the responsibility of the installer.
- Re-stocking fees may apply to items returned that are found to be non-defective. Complete units will also attract a re-stocking fee if returned for credit, regardless if a defect is discovered or not. Re-stocking fees may vary depending on the condition of the item being returned, and whether it can be determined as in brand new condition. The warranty terms do not entitle customers to an automatic full refund. For more details on returns procedures and re-stocking fees, contact the agent.
- Items with physical signs of surge damage are not covered by warranty. Items with visible signs of surge damage will only be covered by warranty if photographic evidence is provided from site, showing surge protection has been installed.

Full warranty terms and conditions available upon request to AES Technical Department.

PRODUCT MAINTENANCE

Bug ingress is a common issue in unit failures. Ensure that all components are sealed accordingly and check occasionally. **(Do not open the panel in the rain / snow unless correctly equipped to keep the internals dry. Ensure the unit is securely closed after maintenance)**

SIM MAINTENANCE

If using a pre-pay casual SIM card it will need topped up occasionally. It is recommended to advise the home owner / end user to register the SIM card on the provider's web site if available. Most major networks allow registration of card payment details for an auto top up feature, which means they will automatically top up your intercom when the balance runs low or in some cases, they offer a low balance reminder to be sent if they do not wish the auto top up feature.

ENVIRONMENTAL INFORMATION

The equipment that you bought has required the extraction and use of natural resources for its production. It may contain hazardous substances for the environment. In order to avoid the dissemination of those substances in our environment and to diminish the pressure on the natural resources, we encourage you to use the appropriate take-back systems. Those systems will reuse or recycle most of the materials of your end-of-life equipment.



The crossed-bin symbol marked in your device invites you to use those systems.

If you need more information on the collection, reuse and recycling systems, please contact your local or regional waste administration. You can also contact AES Global Ltd for more information on the environmental performances of our products.

This product is not a complete product until fully installed. It is therefore considered a component part of an overall system. The installer is responsible to check that the end installation complies with local regulatory requirements. This equipment forms part of a "fixed installation".

STILL HAVING TROUBLE?
Find all of our support options such as Web Chat, Full Manuals, Customer Helpline and more on our website:

WWW.AESGLOBALONLINE.COM

+44 (0)288 639 0693